

Symphony Plus™ ice and water dispenser

C/E 25 and 50 CI series countertop with Chewblet® ice machine



SensorSAFE™ infrared dispense



SensorSAFE not recommended for use with clear containers or for applications in direct sunlight

Model configurations				
Ice storage capacity	Dispense	Ice machine cooling	Voltage V/Hz	Item number
11.4 kg (25 lb)	Lever	air	220/60	C25CI425A-L
	Lever	air	230/50	E25CI425A-L
	SensorSAFE	air	220/60	C25CI425A-S
	SensorSAFE	air	230/50	E25CI425A-S
22.7 kg (50 lb)	Lever	air	220/60	C50CI425A-L
	Lever	air	230/50	E50CI425A-L
	SensorSAFE	air	220/60	C50CI425A-S
	SensorSAFE	air	230/50	E50CI425A-S

Ice-only available, add -I
Example: E25CI425A-LI

Ice production		
Temperatures air/water	21/10 C (70/50 F)	32/21 C (90/70 F)
Air-cooled	186.1 kg (410 lb)	140.7 kg (310 lb)
Energy consumption per 45.4 kg (100 lb) ice	N/A	6.0 kWh air-cooled
Water consumption	45.4 L (12.0 gal) of potable water per 45.4 kg (100 lb) of ice	

Features

11.4 or 22.7 kg (25 or 50 lb) ice storage capacity

Counter-height removable air-cooled ice machine with up to 186 kg (410 lb) daily production of Chewblet ice

- modular ice machine slides out from behind lower front panel
- soft, chewable, compressed nugget ice is preferred over cubes¹ and is ideal for patient care
- Quiet Night™ sleep mode turns off ice machine when idle

Designed with sanitation in mind

- automatic self-flushing of ice machine removes impurities
- drain cup provides internal air gap for added protection of food zone components from drain line contaminants
- Agion® silver-based antimicrobial provides protection of key ice and water contact components²
- one-hand lever or SensorSAFE infrared ice dispense

Dependable design, easy to service and clean

- cleaning and sanitizing of entire machine takes only 1 hour
- LED control board provides at-a-glance machine status
- panels are easily removed for accessibility to all components
- ice machine parts are common across all Symphony Plus dispensers
- stainless steel evaporator and auger deliver long life

Environmentally responsible

- continuous ice making process uses less electricity and water

Durable, attractive dispenser

- stainless steel cabinet with accent trim
- poly drain pan, grille and dispenser lid are corrosion-resistant
- secured top lid

Easy installation and industry's best warranty

- comes fully assembled and installs with three easy connections – electric, water and drain
- warranty – 3 years parts and labor, 5 years compressor parts³

Accessories

Base stand with or without factory installed water filter (refer to form# 7010)

10.16 cm (4.00") leg kit (item# 00188417)

Pressurized water sanitizing kits (refer to form# 6830)

Water filters (refer to form# 9905)

Additional Symphony Plus accessories (refer to price list)

Job _____
Item _____

Follett Europe Polska Sp. z o.o.
Mokry Dwór 26C 83-021 Wiślina, Poland
+48 (58) 785-6140 | Fax: +48 (58) 785-6159
folletteurope.com

801 Church Lane | Easton, PA 18040, USA
1.610.252.7301 | Fax: +1.610.250.0696 | follettice.com



Specification

Ice storage capacity	25 Series – 11.4 kg (25 lb) 50 Series – 22.7 kg (50 lb)
W1 Width, dispenser	53.3 cm (21.00")
W2 Width, base stand accessory	57.8 cm (22.75")
D1 Depth, entire dispenser	61.0 cm (24.00")
D2 Depth, drain pan	17.78 cm (7.00")
D3 Depth, base stand accessory	61.9 cm (24.38")
H1 Height	25 Series – 91.4 cm (36.00") 50 Series – 101.6 cm (40.00")
H2 Dispense height clearance	26.7 cm (10.50")
H3 Height, base stand	83.8 cm (33.00")
Ventilation clearance	7.62 cm (3.00") all sides
Service clearance	30.5 cm (12.00") top, 15.24 cm (6.00") left side
Utility connection location	back or bottom
C1 220 V/60/1 ("C" models) / 230 V/50/1 ("E" models) electrical	5.5 amps, 0.8 kW 2.4 m (8') cord only
C2 Potable water inlet	3/8" FPT
C3 Drain	3/4" MPT
Ice production at 70 F (21 C) air, 50 F (10 C) water	60 Hz models – 186 kg (410 lb) 50 Hz models – 154 kg (339 lb)
Ice production at 90 F (32 C) air, 70 F (21 C) water	60 Hz models – 145 kg (319 lb) 50 Hz models – 120 kg (264 lb)
Heat rejection	5000 BTU/hr
Air temperature	10 - 38 C (50 - 100 F)
Water temperature	7 - 32 C (45 - 90 F)
Potable water pressure	69 - 483 kpa (10 - 70 psi)
Refrigerant	R404a for 60 Hz models R449a for 50 Hz models
Approximate net weight	85 kg (188 lb)
Approximate ship weight	103 kg (226 lb)
Approximate ship weight, base stand accessory	50 kg (110 lb)

NOTE: For indoor use only

SHORT FORM SPECIFICATION: (Choose one) ___ Ice and water or ___ ice-only dispenser to be Follett® automatic load in countertop configuration, with ___ 11.4 kg (25 lb) or ___ 22.7 kg (50 lb) of storage. Ice machine to produce chewable nugget ice. Ice machine removable for cleaning and maintenance. Ice machine equipped with automatic self-flushing and Quiet Night sleep mode. Dispenser to have automatic bin level control to start and stop ice machine. Storage area to be insulated with CARB compliant non-HFC foam. 2.4 m (8') cord only. 230 V models CE and EU food contact compliant.

Dimensional drawing

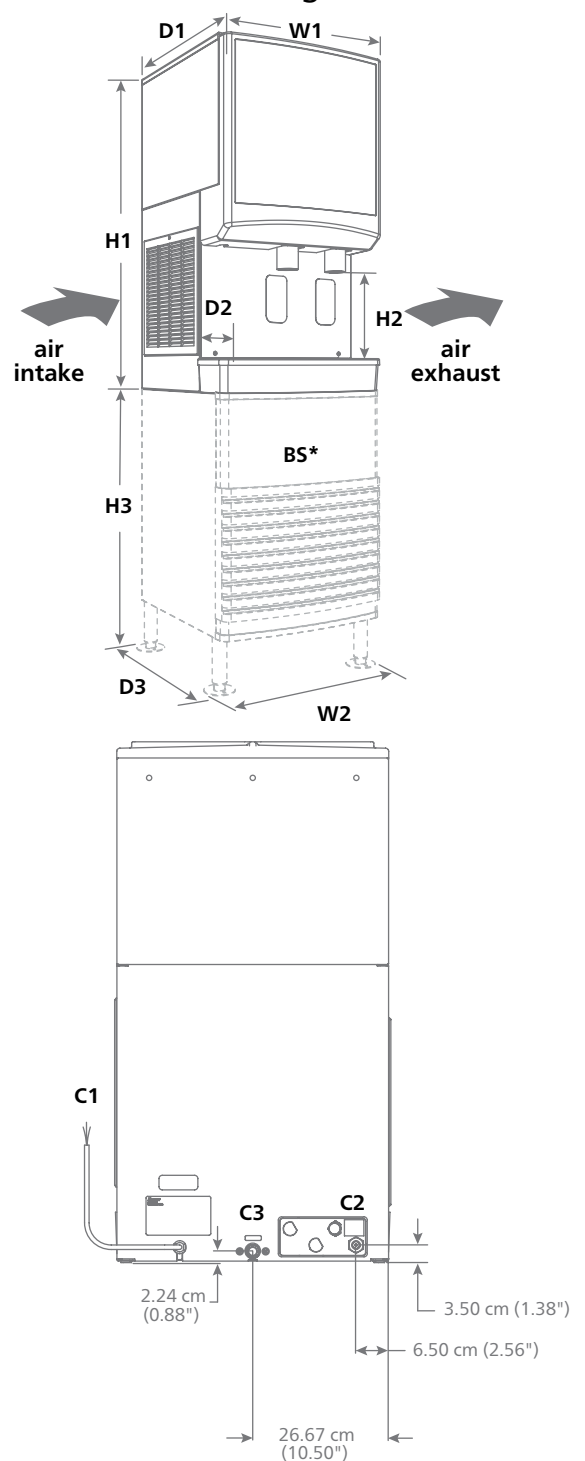

BS* – Base stand sold separately; measurements shown are with base stand legs at lowest position.

See dispenser detail sheet, form# 6675, for counter cut outs.

- 1 Independent third party studies. Contact Follett for details.
 - 2 Disclaimer: Antimicrobial protection is limited to the treated components and does not treat water or ice.
 - 3 Refer to price list for additional warranty information.
- Agion is a registered trademark of Sciescent LLC.
 SYMPHONY PLUS, SENSORSAFE and QUIET NIGHT are trademarks of Follett LLC.
 CHEWBLET and FOLLETT are registered trademarks of Follett LLC, registered in the US.
 Follett reserves the right to change specifications at any time without obligation. Certifications may vary depending on country of origin.

C/E 25/50 CI series countertop

7090-201912 | © Follett LLC



Follett Europe Polska Sp. z o.o.
 Mokry Dwór 26C 83-021 Wiślina, Poland
 +48 (58) 785-6140 | Fax: +48 (58) 785-6159
 folletteurope.com

801 Church Lane | Easton, PA 18040, USA
 1.610.252.7301 | Fax: +1.610.250.0696 | follette.com

FOLLETT®